



**ATLANTA
INDUSTRIES**



ATLANTA

PRE-PACKAGED FIRE PUMP

- Intergrated design
- Compatible with intelligent buildings
- Space savings for developer in terms of space, materials & labor cost
- Philippine Bureau of Fire Approved



SCAN & VISIT OUR WEBSITE



Direct-driven Fire Pump(with jockey pump)



Direct-driven Fire Pump



Closed-coupled Fire Pumps

OUR PERSISTENCE IN EXCEPTIONAL

QUALITY ASSURES PERFECT FIRE SAFETY.

Features of Firefighting Pump:

1. Atlanta Pre-Packaged Fire Pump is in total portable design and all mechanical components and control system are manufactured independently and assembled systematically and the assembly can be adjusted per the site space, installation and transportation. It is highly customized.
2. Atlanta Pre-Packaged Fire Pump adopted multiple protection mechanism and reserved multi-function terminals in control circuit design, which can satisfy integrated needs of disaster prevention, monitoring and security systems of all types of building and the unit status are easily under control.
3. Atlanta Pre-Packaged Fire Pump can be added with automatic testing system and user can set automatic testing cycle at wish, simple, convenient and trouble-free, that will ensure the functions of the unit are normal in all aspects and stay away from the threat of fire.
4. Atlanta Pre-Packaged Fire Pump can be added with pressure auxiliary pump, which can be used to replace the main pump in maintaining pressure and supplement water when the line is slightly lose pressure and when the water need is minimal, and it can minimize the times of starting of main firefighting pump, as well as saving the power consumed by operation of main pump, as well as unnecessary noise of operation of main firefighting pump that will help to maintain living quality.
5. Atlanta Industries, Inc. has installed professional consulting persons to answer any question customers may have and you are welcome to call us to ask for literature and Use / Service Manual.

Application:

- ✓ **Indoor/ outdoor hydrant pump**
- ✓ **Spray pump**
- ✓ **Foam pump**
- ✓ **Suction pump**
- ✓ **Intermediate pump**
- ✓ **Connecting delivery pump and all kinds of firefighting pumping set.**

Special Flow Meter of Firefighting Pump

Diameter mm	40 mm	50 mm	65 mm	80 mm	100 mm	125 mm	150 mm
Rated Flow Range (L/min)	110 } 550	220 } 1100	450 } 2200	700 } 3300	900 } 4500	1200 } 6000	1200 } 10000
Connector Thread (Internal Thread of Pipe)	1 1/2"	2"	2 1/2"	3"	4"	5"	6"

Flow Meter Installation Instructions:

1. Length of flow regulating pipe is 6 times of pipe diameter (6D). Length of Testing Pipe is 5 times of pipe diameter (5D).
2. When flow meter is in use and is in the piping manner in Fig. 1, Gate Valve A must be fully opened with Gate Valve B serves to control flow.
3. Metering by-pass of flow meter shall not have length or shape changed without authorization so to avoid affecting the accuracy of metering.

D1: Outlet piping
D2: ID of Flow Pipe

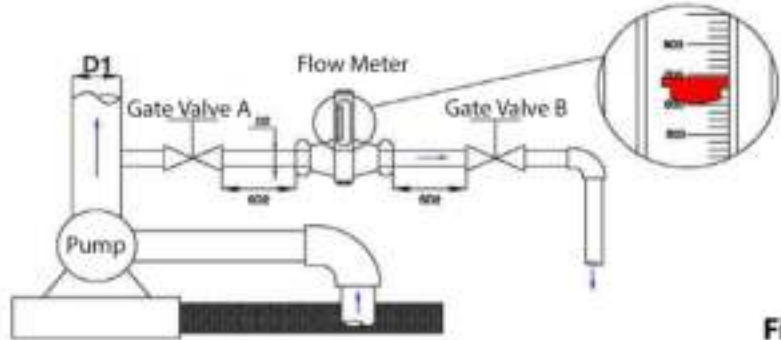

Fig. 1

Firefight Pump Set



● Direct-Driven Fire Pump Set (with Jockey pump)



● Direct-Driven Fire Pump Set



● Close-Coupled Fire Pump Set (DFAP)

Atlanta TS Fire fighting Pump built to CNS Standard

1. Pump Main Body

- (1) Construction: Centrifugal Pump meeting ISO standard. (CNS 9817.B4052-2-2. 1-2.10)
- (2) Performance: [CNS 8917 B 4052-4.1 (1)~ (4)]
 - Full head of rated discharge flow reached 100% to 110% of designed full head.
 - When discharge flow reached 150% of rated discharge flow, the full head is above 65% of rated head.
 - Full closed head within 140% of rated head.
- (3) Rated efficiency of firefighting pump meets the single stage coupled pump and multi-stage coupled pump under ISO 2858 and CNS2138 standards.
- (4) Pump Main Body: Made of gray case iron piece and met [CNS2472 G3038] standard.
- (5) Impeller: Made of Gray Cast Iron and met [CNS2472 G3038]. (Option: Bronze casting met CNS4125 H30571 standard.
- (6) Main shaft: Made of stainless steel met CNS4000 G3092 standard
- (7) Pump body can sustain 1.5 times of highest water pressure and no leak found after 3 minutes pressurizing
- (8) Bearing: Double covers ball bearing, lubricant enclosed bearing inside.
- (9) Shaft Seal: Mechanical Shaft Seal (free of suction of air or serious water leak).

2. Electrical Drive [CNS 8918 B4053]

- (1) Use high performance Tatum or Teco Electric Motor with specification meeting CNS89418, CNS14400.
- (2) Nothing abnormal after continuous 8 hours operation and free of trouble or overheating after operating for one hour at 10% more than rated output and electric motor works properly. High resistance to mechanical strength and electrical performance and convenient in operation, service, parts replacement and repair.
- (3) Electrical performance of electric motor meets the requirement as established by National Fire Agency for review of Firefighting Pump.
- (4) Starting Manner
 - Direct start for electric motor smaller than 11kw (15 HP).
 - Y- Δ (Star-Delta) starting for motor of 11kw (15 HP) or larger electric motor.
- (5) Insulating Resistance:
 - 0.1M Ω or higher for motor voltage under 300V and earth voltage under 150V.
 - 0.2M Ω or higher for electric motor of voltage 300V or less and other than the above.
 - 0.4M Ω or higher for electric motor of voltage above 380V.

3. Control Panel [CNS8919 B 4054-2(1)(2)(3)]

- (1) When power supply is switched to emergency power supply. It can be operated continuously without starting again.
- (2) Indicating lamp: Power (white), Starting (red), Priming Tank under level (orange) Overload (orange) Power indicating lamp (white) for electromagnetic valve switch, used in operation circuit.
- (3) Operation Switch: Starting push button switch, stop push buttons switch, Reset switch, auto-stop-Manual select for starting switch.
- (4) Alarm devices: Electric motor overload, Priming pump low level alarm buzzer, the stop, sounding and resuming is operated directly and manually and will not cause motor to stop automatically due to alarm
- (5) Instrument: Potentiometer, Voltmeter.
- (6) Terminal: Starting signal input panel, Priming tank low level detection input terminal, Alarm signal input terminal, Pump operating signal output terminal, Earthing terminal, No-fuse breaker, Electromagnetic switch, Thermal relay.
- (7) Material used: SS41 with corrosion proof bake paint treatment (Option: SUS304).
- (8) Wiring: Low voltage wiring in control panel use 600 PVC Insulating wire (Option: Low smoke toxic free/ flame resisting insulating wire).
- (9) Spare parts: Control panel shall be equipped with the following spare material: Spare fuse, Wiring diagram and Operation Instruction.
- (10) Labeling: Control panel shall be marked in non-erasable manner the following items: Mark of manufacturer or brand, Item name and model number, Time of manufacturing, Commodity serial number, Rated voltage, Motor Capacity.

4. Priming Device [CNS8919 B 4054-3(1)(2)(3)(4)]

- (1) Equipped items: Priming water tank, Overflow draining pipe, Draining pipe (incl. stop cock) Priming pipe (incl. check valve and stop cock), Level gauge.
- (2) Reduce alarm device, Automatic water supply device (incl. check valve and float).
- (3) Water tank made of stainless steel, anti-corrosion bake paint coated to 0.5 mm thickness, capacity is 100 L effective storing capacity.
- (4) Piping diameter: Feed water pipe: 15A, Effluent draining pipe: 50A, Priming pipe: 40A.
- (5) Level dropping alarm device: With float switch or electrode manner, where alarm is triggered when the storage tank water level reduced to 1/2.
- (6) Storage tank supply water automatically through Ball Tap.

5. Draining Device for preventing water temperature rise [CNS8919 B 4054-3(3)]

- (1) When the level of storage tank is lower than the suction port of water pump, Water Filling Tank (Supplementing Tank) will be adopted. The Draining Pipe for preventing temperature rise of water connect the primary side of check valve of filling pipe and a limit flow hole is installed, so that water can be discharged to the water filling tank or basin while the water pump is operating
- (2) If the Water Filling Tank is not installed, the drain pipe for preventing water temperature rise will be connected from the primary side of check valve of filling pipe and flow limiting hole is installed, so that water can be discharged to ambient temperature storage tank while the water pump is starting.
- (3) The Piping of the draining pipe that is for preventing rise of water temperature does not install any valve and is in 15A or larger diameter.
- (4) The flow in the heat escape pipe helps water pump to operate continuously under fully closed situation and the temperature rise of water inside water pump will not be more than 30 C.

6. Starting Hydraulic Switch Device (Pressure Tank)[CNS8919 B 4054-5(1)-(5)]

- (1) Starting Pressure Tank capacity 100L Structure meets pressure vessel standard.
- (2) Starting Pressure Tank structure meets standard pressure standard of 10kg/cm² of pressure vessel.
- (3) Starting Pressure Tank uses 25A diameter pipe to connect with secondary piping of check valve at the output side of water pump and a stop cock installed in between.
- (4) Pressure gauge, hydraulic switch and starting drain valve on starting pressure tank.
- (5) Pressure gauge is a Class 1.5 or higher precision and pressure range is between 0-10kg/cm² and 0-20kg/cm².
- (6) Applicable pressure range of pressure switch: 1-10kg/cm² , 5-20kg/cm²; motion pressure difference 1-3kg/cm² and 3-5kg/cm² and water temperature is between -30°C - 100°C.
- (7) Equipped with Safety Valve can avoid the unusual pressure rise in the tank to ensure safety. The normal pressure range is 7-13kg/cm² and range can be set to 0-15kg/cm².

7. Water Pump Performance Testing Device [CNS 8919 B 4054-4(1)]

- (1) Piping of testing device is installed to the branch of primary side of check valve at the output side of water pump and flow adjusting valve and flow meter required for testing flow are installed in between and flow regulating pipe.
- (2) Use of pressure difference flow meter can measure and read rated flow and 150% flow range directly.
- (3) Compound gauge (Vacuum Gauge) precision above Class 1.5 (Option: curved pipe(shock absorbing and cock switch).
- (4) Pressure Gauge, Class 1.5 or higher precision (Option: curved pipe (shock absorbing).

8. Valve/ Main piping element [CNS8919 B 4054-6]

- (1) Check Valve: Use Atlanta T5 patented multi-function 3 in 1 buffer check valve. Subject to pressure equipment, select 10K/ 16K valve with flow direction indicating symbol and in non-erasable manner, Material: Cast iron.
- (2) Gate valve: Complying with JIS standard, select 10K/ 16K valve depends on equipment pressure and is set with open/ close direction mark. Material: Cast iron (Option:20K).
- (3) Valve can sustain 1.5 time of the max. head pressure of the pump with the feature of heat resisting and corrosion resisting and is complying with all requirements under firefighting law and regulations.
- (4) Vibration resistant flexible hose: Complying with JIS standard and select 10K/16K pressure resisting class subject to the pressure of equipment. Material: Stainless Steel (Option: 20K).



Names of Parts and Components for Atlanta Pre-Packaged Fire Pump

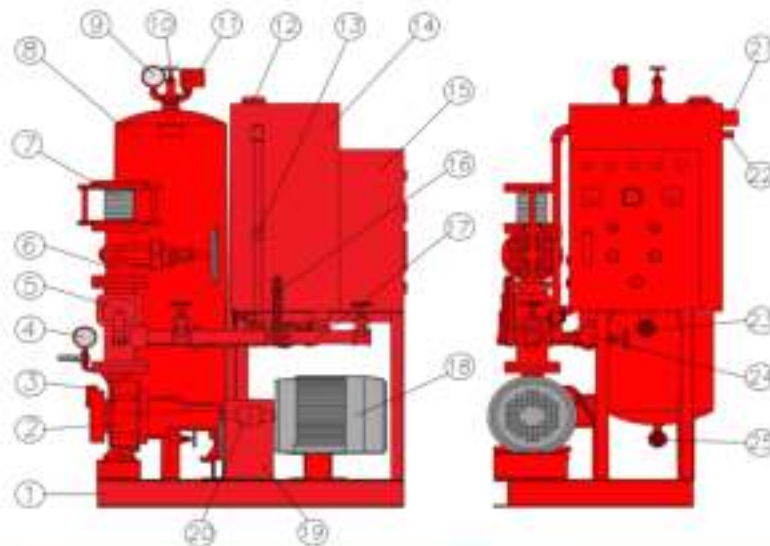

No.	Name	Description
1	Base plate	Base plate supporting the firefighting pump set and provide the base holes for connecting and fixing with ground (Material: steel)
2	Pump main body	Coupled end suction centrifugal pump, smooth both inside and outside, free of sand pit, crack or uneven thickness. Good impeller balance and smooth in fluid channel (horizontal, centrifugal and single stage pump). Pump body: made of gray cast iron, meeting CNS 2472 G3038 standard. Impeller: made of gray cast iron, meeting CNS 2472 G3038 standard. Main shaft: made of stainless steel, meeting CNS 4000 G3092 standard. Bearing: Use double cover ball bearing, lubricant covered bearing inside. Shaft seal: Mechanical Seal (no risk of sucking air or serious leak of water).
3	Compound gauge	Indicating the vacuum of suction of pump at time of operation of the set.
4	Pressure gauge	Indicating the pressure of pump piping when the pump is in operation.
5	Multi-Function check valve	Preventing water hamper when the pump is stopped and maintain the reasure in the pipe (flow direction indicated).
6	Outlet Gate Valve	Control of the outlet flow and switch of pump.
7	Vibration resisting hose	Prevent the vibration wave of pump to transit along piping and cause resonance.
8	Pressure tank	Cap. 100L, Rated Pressure: 10 kg/cm ² , Diameter: 25A, T=3.0 mm (steel).
9	Pressure Gauge	Indicating the piping pressure at time of operation and stop of pump set.
10	Pressure relief safety valve	(1/2") for preventing abnormal rise of pressure in the tank to ensure safety.
11	Pressure controller	Allowing the setting of pressure of pump of starting and stopping of operation.
12	Level Detector	Electrode type for detecting water level of supplementing tank and when it is too low, the alarm will be triggered.
13	Heat Escape Pipe	Plate Temperature Discharging Valve - This device is for preventing internal temperature rising for 30 or more when the water pump is running continuously with all outlet port closed
14	Supplement Tank	Capacity: 100 liters, provide water pump with supplementary water level to facilitate starting up. T=1.6mm (material: Steel)
15	Control Box (or Console)	ISO Certified genuine part. Alarm, Firefighting Failure Display and similar automatic circuit control device. (T=1.6 mm, material: SS41)
16	Flow Meter	Made in Taiwan, Joining with Compound Gauge and Pressure Gauge, it can measure the flow and pressure of pump.
17	Flow Test Tube	For use in testing firefighting set an ordinary time and the direction may be adjusted per the space of machine room.
18	Electric Motor	Worldwide renowned Tatung or TECO brand motor. Both of them can run continuously for 8 hours without any irregularity. When running at 110% of rated output for one hour, there would not be any trouble or overheating. Parts and components are well fixed. The equipment is built for solid and durable operation. They are easy to service and easy in replacing parts.
19	Driver Protecting Guard	This is for preventing touching by mistake and to keep the coupler from being damaged by external force.
20	Coupler	This is the device for transmitting output force of motor.
21	Effluent Pipe	This is the device for maintaining the water level I tank so that it would not be overflowed. (50A)
22	Supplementing Pipe	The pipe is for connecting external water supply to supplementary tank and float switch control is adopted (15A)
23	Draining Valve	For draining water at time of service and clearing of supplementary tank.
24	Pump supplementing pipe	Connecting pump outlet and supplementing tank and it frees the trouble of filling water outside of the pump.
25	Draining Valve	For draining water when the pressure tank is full or discharge pressure when testing automatic start.

2P Single Stage Firefighting Pump Specifications:

No.	Model No.	HP	Dia (in)		Head (M)	Flow Rate (LPM)	Base Dim (mm)		Unit Max Dim (mm)			Weight (KG)
			Inlet	Outlet			Length	Width	Length	Width	Height	
1	FAP-3000	10HP (7.5KW)	3/4	3/4	60	300	1000	650	1150	790	1610	220
					63	270						
					63	150						
2	FAP-3000C	10HP (7.5KW)	3/4	3/4	57	460	1000	650	1150	790	1610	220
					63	300						
3	FAP-3000A	15HP (11KW)	3/4	3/4	84	300	1100	700	1200	850	1610	372
4	FAP-3000B	15HP (11KW)	3/4	3/4	90	300	1100	700	1200	850	1610	372
5	FAP-3001	15HP (11KW)	3/4	3/4	60	460	1100	700	1200	850	1610	372
6	FAP-4001A	15HP (11KW)	4	4	49	800	1100	700	1200	850	1610	372
					51	750						
					53	720						
					54	640						
7	FAP-3002A	20HP (15KW)	3/4	3/4	94	400	1100	700	1200	850	1610	450
					97	300						
8	FAP-3002B	20HP (15KW)	3/4	3/4	100	300	1100	700	1200	850	1610	450
9	FAP-3002C	20HP (15KW)	3/4	3/4	107	300	1100	700	1200	850	1610	450
10	FAP-4002A	20HP (15KW)	4	4	60	900	1100	700	1200	850	1610	450
					62	770						
					64	700						
					65	640						
					66	590						
					67	560						
11	FAP-4002B	20HP (15KW)	4	4	54	1050	1100	700	1400	850	1610	450
					55	1000						
					59	910						
					60	850						
					61	800						
					39	1410						
12	FAP-4021A	20HP (15KW)	4	4	40	1330	1100	700	1400	850	1610	450
					42	1200						
					43	1100						
13	FAP-4022A	20HP (15KW)	4	4	80	460	1100	700	1300	850	1610	450
					82	400						
14	FAP-3003A	25HP (18.5KW)	3/4	3/4	110	300	1100	700	1200	850	1610	510
15	FAP-3003B	25HP (18.5KW)	3/4	3/4	126	300	1100	700	1200	850	1610	510
16	FAP-3003C	25HP (18.5KW)	3/4	3/4	128	300	1100	700	1200	850	1610	510
17	FAP-4003	25HP (18.5KW)	4	4	48	1350	1100	700	1400	850	1610	510
					50	1200						

2P Single Stage Firefighting Pump Unit Specifications:

No.	Model No.	HP	Dia (in)		Head (M)	Flow Rate (LPM)	Base Dim (mm)		Unit Max Dim (mm)			Weight (KG)
			Inlet	Outlet			Length	Width	Length	Width	Height	
18	FAP-4003A	25HP (18.5KW)	4	4	76	850	1100	700	1400	850	1610	510
					78	770						
					81	640						
19	FAP-4003B	25HP (18.5KW)	4	4	60	1200	1100	700	1400	850	1610	510
					63	1100						
					66	1000						
					69	910						
					70	900						
72	800											
20	FAP-6000A	25HP (18.5KW)	6	6	27	2200	1200	900	1700	1100	1610	510
21	FAP-3004A	30HP (22KW)	3/4	3/4	131	300	1100	700	1300	850	1610	550
22	FAP-3004B	30HP (22KW)	3/4	3/4	137	300	1100	700	1300	850	1610	550
23	FAP-4004	30HP (22KW)	4	4	66	1260	1200	700	1400	850	1610	550
					72	1100						
24	FAP-4004A	30HP (22KW)	4	4	74	1000	1200	700	1400	850	1610	550
					70	1100						
25	FAP-4004B	30HP (22KW)	4	4	75	900	1200	700	1450	900	1610	550
					80	925						
					82	880						
					83	840						
					85	760						
87	640											
26	FAP-4004D	30HP (22KW)	4	4	80	1000	1200	700	1400	900	1610	550
					84	850						
27	FAP-4031A	30HP (22KW)	4	4	56	1350	1200	700	1400	900	1610	550
					64	1200						
					65	1150						
66	1100											
28	FAP-6001B	30HP (22KW)	6	6	38	2200	1200	700	1700	1050	1610	550
29	FAP-3005A	40HP (30KW)	4	4	147	300	1200	700	1500	900	1610	720
30	FAP-4024A	40HP (30KW)	4	4	108	950	1200	700	1400	900	1610	720
					116	800						
31	FAP-4010A	40HP (30KW)	4	4	81	1200	1200	700	1450	900	1610	720
					82	1150						
					84	1120						
					86	1080						
					87	1050						
					89	1000						
92	910											
32	FAP-4010B	40HP (30KW)	4	4	90	1080	1200	700	1450	900	1610	720
					92	1000						
					95	910						

2P Single Stage Firefighting Pump Unit Specifications:

No.	Model No.	HP	Dia (in)		Head (M)	Flow Rate (LPM)	Base Dim (mm)		Unit Max Dim (mm)			Weight (KG)
			Inlet	Outlet			Length	Width	Length	Width	Height	
33	FAP-4032A	40HP (30KW)	4	4	69	1680	1200	700	1600	900	1610	720
					70	1650						
					72	1550						
					73	1500						
					74	1450						
					75	1400						
					76	1330						
					77	1200						
79	1100											
34	FAP-4032B	40HP (30KW)	4	4	62	1680	1200	700	1600	900	1610	720
35	FAP-6001A	40HP (30KW)	6	6	46	2200	1200	700	1700	1050	1610	720
					50	1750						
36	FAP-4011A	50HP (37KW)	4/6	4/6	99	1100	1300	750	1460	950	1610	810
					102	910						
37	FAP-4011B	50HP (37KW)	4/6	4/6	117	1100	1300	750	1460	950	1610	810
					120	910						
38	FAP-4033A	50HP (37KW)	4/6	4/6	75	1960	1300	750	1600	930	1610	810
					76	1820						
					78	1680						
					81	1450						
39	FAP-4034A	50HP (37KW)	4/6	4/6	88	1550	1300	750	1500	880	1610	810
					89	1450						
					91	1200						
					92	1100						
					94	900						
40	FAP-4034B	50HP (37KW)	4/6	4/6	94	1460	1300	750	1500	880	1610	810
					96	1350						
41	FAP-6002A	50HP (37KW)	6	4/6	54	2700	1300	750	1900	1150	1610	810
					56	2400						
					58	2200						
					59	2000						
42	FAP-3007A	60HP (45KW)	3/4	3/4	151	850	1300	750	1500	950	1610	890
					158	600						
43	FAP-4041A	60HP (45KW)	4/6	4/6	78	2100	1300	750	1500	920	1610	890
					80	1900						
					81	1820						
					83	1680						
					86	1100						
44	FAP-4042A	60HP (45KW)	4/6	4/6	96	1680	1300	750	1500	1000	1610	890
					98	1450						
					99	1330						
45	FAP-4042B	60HP (45KW)	4/6	4/6	96	1350	1300	750	1450	930	1610	890
					98	1100						

2P Single Stage Firefighting Pump Unit Specifications:

No.	Model No.	HP	Dia (in)		Head (M)	Flow Rate (LPM)	Base Dim (mm)		Unit Max Dim (mm)			Weight (KG)
			Inlet	Outlet			Length	Width	Length	Width	Height	
46	FAP-4042C	60HP (45KW)	4/6	4/6	115 120	1450 1350	1300	750	1450	930	1610	890
47	FAP-4043A	60HP (45KW)	4/6	4/6	104 106 110	1350 1200 1080	1300	750	1500	950	1610	890
48	FAP-4043B	60HP (45KW)	4/6	4/6	107 109	1350 1200	1300	750	1500	1000	1610	890
49	FAP-6003A	60HP (45KW)	6	6	66 68 69 70	2700 2400 2200 2000	1300	750	1500	1100	1610	890
50	FAP-6003B	60HP (45KW)	6	6	54	3300	1300	750	2350	1130	1590	890
51	FAP-6003C	60HP (45KW)	6	6	78	2400	1300	750	1700	1100	1610	890
52	FAP-4051A	75HP (55KW)	4/6	4/6	92 94 96 98 99 103 106	2100 2000 1900 1820 1800 1480 1350	1200	900	1650	1050	1700	1000
53	FAP-4052A	75HP (55KW)	4/6	4/6	121	1350	1200	900	1500	1050	1700	1000
54	FAP-4052B	75HP (55KW)	4/6	4/6	122 125	1520 1350	1200	900	1500	1050	1700	1000
55	FAP-4052C	75HP (55KW)	4/6	4/6	120	1650	1200	900	1500	1050	1700	1000
56	FAP-4052D	75HP (55KW)	4/6	4/6	138	1200	1200	900	1500	1050	1700	1000
57	FAP-6004A	75HP (55KW)	6	6	82 84 85 86	2700 2400 2200 2000	1200	900	1550	1200	1770	1000
58	FAP-6004B	75HP (55KW)	6	6	85 86	2240 2100	1200	900	1550	1200	1770	1000
59	FAP-6005	75HP (55KW)	6	6	75 79	2700 2400	1200	900	1550	1200	1770	1000
60	FAP-6006A	75HP (55KW)	6	6	64	3300	1200	900	1550	1200	1655	1000
61	FAP-4053A	100HP (75KW)	4/6	4/6	117 118 120 122	2000 1930 1750 1460	1500	1000	1800	1330	1840	1560
62	FAP-4053B	100HP (75KW)	4/6	4/6	115	2200	1500	1000	1800	1330	1840	1560

2P Single Stage Firefighting Pump Unit Specifications:

No.	Model No.	HP	Dia (in)		Head (M)	Flow Rate (LPM)	Base Dim (mm)		Unit Max Dim (mm)			Weight (KG)
			Inlet	Outlet			Length	Width	Length	Width	Height	
63	FAP-4061A	100HP (75KW)	4/6	4/6	134	1750	1500	1000	1800	1330	1840	1560
					136	1600						
					140	1350						
64	FAP-4061B	100HP (75KW)	4/6	4/6	150	1200	1500	1000	1800	1330	1840	1560
					153	1080						
65	FAP-4061C	100HP (75KW)	4/6	4/6	159	1460	1500	1000	1800	1330	1840	1560
					161	1350						
66	FAP-4061D	100HP (75KW)	4/6	4/6	153	1350	1500	1000	1800	1330	1840	1560
67	FAP-6011A	100HP (75KW)	6	6	100	2700	1500	1000	1820	1330	1840	1560
					102	2400						
					105	2300						
68	FAP-6011B	100HP (75KW)	6	6	87	3300	1500	1000	1820	1330	1840	1560
					93	2700						
69	FAP-6011C	100HP (75KW)	6	6	110	2400	1500	1000	1820	1330	1410	1560
70	FAP-4071A	125HP (90KW)	4/6	4/6	140	1700	1500	1000	1700	1200	1950	1600
71	FAP-6021A	125HP (90KW)	6	6	123	3000	1500	1000	1820	1330	1840	1600
					125	2700						
					127	2400						
72	FAP-6021B	125HP (90KW)	6	6	90	3700	1500	1000	1820	1330	1840	1600
					94	3300						
					99	3100						
					100	2700						
73	FAP-6021C	125HP (90KW)	6	6	130	2400	1500	1000	1820	1330	1840	1600
74	FAP-6021D	125HP (90KW)	6	6	115	2700	1500	1000	1820	1330	1840	1600
					117	2400						
75	FAP-4081A	150HP (110KW)	4/6	4/6	153	2400	1500	1000	1820	1330	2000	1730
76	FAP-6031A	150HP (110KW)	6	6	130	3100	1500	1000	1900	1350	2000	1730
					138	2700						
					140	2400						
77	FAP-6031B	150HP (110KW)	6	6	117	3854	1500	1000	1900	1350	2000	1730
					120	3300						
					127	2700						
					130	2400						
78	FAP-6031C	150HP (110KW)	6	6	94	3900	1500	1000	1900	1350	2000	1730
79	FAP-6041A	175HP (132KW)	6/8	6/8	142	3300	1900	1100	2200	1400	1950	1780
					150	2700						
80	FAP-6041B	175HP (132KW)	6/8	6/8	153	2400	1900	1100	2200	1400	1950	2200
					155	2400						

4P Single Stage Firefighting Pump Set Specifications:

No.	Model No.	HP	Dia (in)		Head (ft)	Flow Rate (LPM)	Base Dim (mm)		Unit Max Dim (mm)			Weight (KG)
			Inlet	Outlet			Length	Width	Length	Width	Height	
1	FAP-4022B	20HP (15KW)	4	4	46 48	1100 800	1300	700	1500	900	1620	550
2	FAP-4003C	25HP (18.5KW)	4	4	60	850	1300	800	1500	1000	1620	600
3	FAP-4031B	30HP (22KW)	4	4	52	1260	1200	750	1400	950	1610	650
4	FAP-8000A	40HP (30KW)	8	6/8	34	3300	1400	900	1500	1200	1800	800
					36	3000						
					38	2600						
					39	2200						
5	FAP-8000B	40HP (30KW)	8	6/8	85	960	1400	900	1500	1200	1610	800
6	FAP-8001	50HP (37KW)	8	6/8	44	3300	1400	900	1500	1200	1610	900
7	FAP-8001A	50HP (37KW)	8	6/8	57	2200	1400	900	1500	1200	1630	900
8	FAP-8002A	50HP (37KW)	8	6/8	91	1350	1500	900	1600	1100	1690	900
9	FAP-8003A	100HP (75KW)	8	6/8	71	3800	1500	1000	2000	1400	1636	1650
					72	3600						
					74	3300						
10	FAP-8003B	100HP (75KW)	8	6/8	84	3000	1500	1000	2000	1400	1636	1650
11	FAP-8003C	100HP (75KW)	8	6/8	95	2400	1500	1000	2000	1400	1636	1650
12	FAP-8004A	125HP (90KW)	8	6/8	82	4000	1600	1100	2100	1500	1636	1700
					83	3600						
					84	3300						
13	FAP-8004B	125HP (90KW)	8	6/8	130	2400	1600	1100	2100	1500	1636	1700
14	FAP-8006A	150HP (110KW)	8	6/8	90	4800	1600	1100	2200	1500	1636	2200
					92	4200						
					93	3800						
					94	3300						
15	FAP-8006B	150HP (110KW)	8	6/8	70	5300	1600	1100	2200	1500	1636	2200
					72	4600						
					90	4800						
16	FAP-8007	175HP (132KW)	8	8	92	4500	1900	1100	2300	1500	1636	2300
					94	4100						
					95	3600						
17	FAP-8007A	200HP (149.2KW)	8	8	88 91	7570 7000	1900	1100	2300	1500	1636	2500
18	FAP-8007B	200HP (149.2KW)	8	8	98 105	5700 4700	1900	1100	2300	1500	1636	2500
19	FAP-8008A	250HP (186.5KW)	8	8	130 131	4500 3800	1900	1100	2300	1500	1636	2650

4P Single Stage Firefighting Pump Set Specifications:

No.	Model No.	HP	Dia (in)		Head (M)	Flow Rate (LPM)	Base Dim (mm)		Unit Max Dim (mm)			Weight (KG)
			Inlet	Outlet			Length	Width	Length	Width	Height	
20	FAP-8008B	250HP (186.5KW)	8	8	110 117	5800 4800	1900	1100	2300	1500	1636	2650
21	FAP-8009B	275HP (205KW)	8	8	147	5000	2200	1300	2400	1750	2530	2800

4P Multi-Stage Firefighting Pump Unit Specifications:

No.	Model No.	HP	Dia (in)		Head (M)	Flow Rate (LPM)	Base Dim (mm)		Unit Max Dim (mm)			Weight (KG)
			Inlet	Outlet			Length	Width	Length	Width	Height	
1	FPD-3000A	10HP (7.5KW)	3/4	3/4	71 75	300 150	1200	700	1500	900	1620	380
2	FPD-3000	15HP (11KW)	3/4	3/4	90	300	1300	700	1500	900	1620	450
3	FPD-4004	30HP (22KW)	4	4	120	300	1650	700	1800	900	1630	700
4	FPD-4032	40HP (30KW)	4/6	4/6	80 85 90	1100 960 840	1400	750	1600	950	1630	900
5	FPD-4052	75HP (55KW)	4/6	4/6	117 122 128	1820 1650 1350	1400	750	1600	950	1620	1100
6	FPD-4053	100HP (75KW)	4/6	4/6	115 120	2700 2400	1500	1000	1700	1200	1500	1750
7	FPD-8005A	250HP (186.5KW)	8	8	200	2700	2000	1200	2300	1400	1636	3000

4P Single Stage Firefighting Pump Unit Specifications (Double suction pump):

No.	Model No.	HP	Dia (in)		Head (M)	Flow Rate (LPM)	Base Dim (mm)		Unit Max Dim (mm)			Weight (KG)
			Inlet	Outlet			Length	Width	Length	Width	Height	
1	FAP-8009A	275HP (205KW)	8	8	147	5000	2200	1500	2500	1700	1970	3200
2	FAP-8010	300HP (224KW)	8	8	106	10000	2400	1500	2650	1650	1820	3500
3	FAP-8010B	300HP (224KW)	8	8	113	8000	2500	1500	3000	1900	2160	3500

- ★ Max. Dimensions above exclude the portion of flow meter testing pipe extended outside of motor.
- ★ Tolerance of the above dimensions is +/- 10 cm.
- ★ Weight above approximate value.
- ★ The above unit dimensions do not change. (Intermediate unit do not have supplementing water tank and water source unit excludes pressure tank).

Control Panel Diagram:

Standard Pump Control Panel

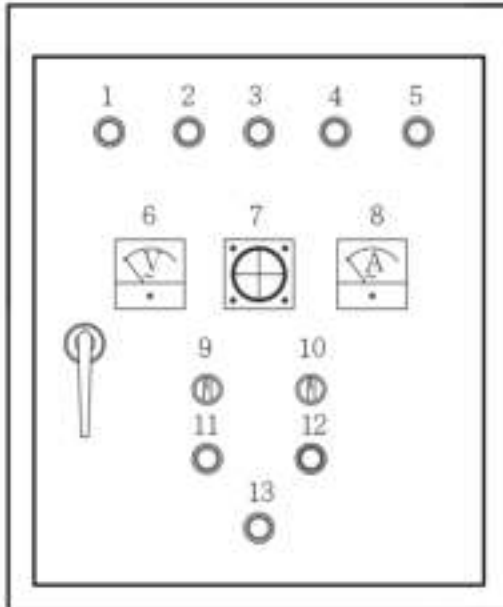

Material: 5541 Bake Paint Box T=1.6mm

Color: Fire Dept. Designated Color

Symbol	Description
1	Power Supply Indicating Lamp (White)
2	Overload Indicating Lamp (Orange)
3	Low Level Lamp (Orange)
4	Motor Operation Indicating Lamp (Red)
5	Motor Stop Indicating Lamp (Green)
6	Voltmeter
7	Alarm Bell
8	Potentiometer
9	Alarm Select Switch (Open-Close)
10	Motor Select Switch (Auto-Stop-Manual)
11	Motor Operation Button
12	Motor Stop Button
13	Low Level Reset Button

Incl. Aux. Pump Control Panel

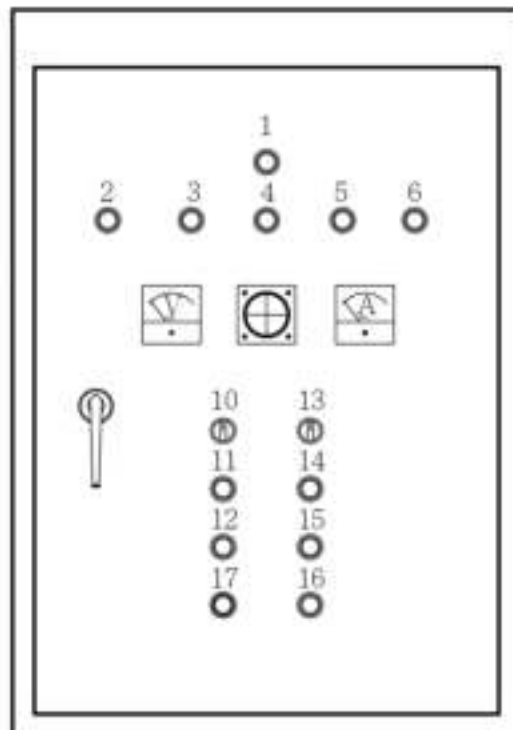

Material: 5541Bke Paint Box T=1.6mm

Color: Fire Dept. Designated Color

Symbol	Description
1	Power Lamp (White)
2	Aux. Pump Operating Indicating Lamp (Red)
3	Overload Indicating Lamp (Orange)
4	Low Level Indicating Lamp (Orange)
5	Motor Operating Indicating Lamp (Red)
6	Motor Stop Indicating Lamp (Green)
7	Voltmeter
8	Alarm Bell
9	Potentiometer
10	Aux. Pump Selecting Switch (Auto-Stop-Manual)
11	Aux. Pump Stop Button
12	Aux. Pump Operation Button
13	Motor Select Switch (Auto-Stop-Manual)
14	Motor Operation Button
15	Motor Stop Button
16	Alarm Select Switch (Open-Close)
17	Water Low Level Reset Button

Notes:

1. When main power supply is 220V, short circuit R-R1, T-T1
2. When main power supply is 440 & 380 V, connect R & T to primary side of Transformer (380V & 440V) and connect R1 & T1 to secondary side 220V of transformer.
3. Points 16 & 17:- When short-circuited, motor Auto operation and Manual stop; when circuit open, motor Auto Op stops.
4. 380V - 440 V power supply, the transformer in the panel provide control power for use in the control panel; external connected firefighting box operating lamp shall have separate transformer ordered to avoid damaging control panel.
5. T1, 1, 2 & 3 on Terminal Block is for use of water source pump.
6. Low voltage wiring inside control panel use 600V PVC insulating wire.

Symbol	Description
	Power Indicator
	Liquid Level Switch
	Overload / Liquid Level Lock-out
	Alarm
	Aux. Relay
	Time Relay
	Electromagnetic
	Switch
	Operation Indication
	Pressure Switch

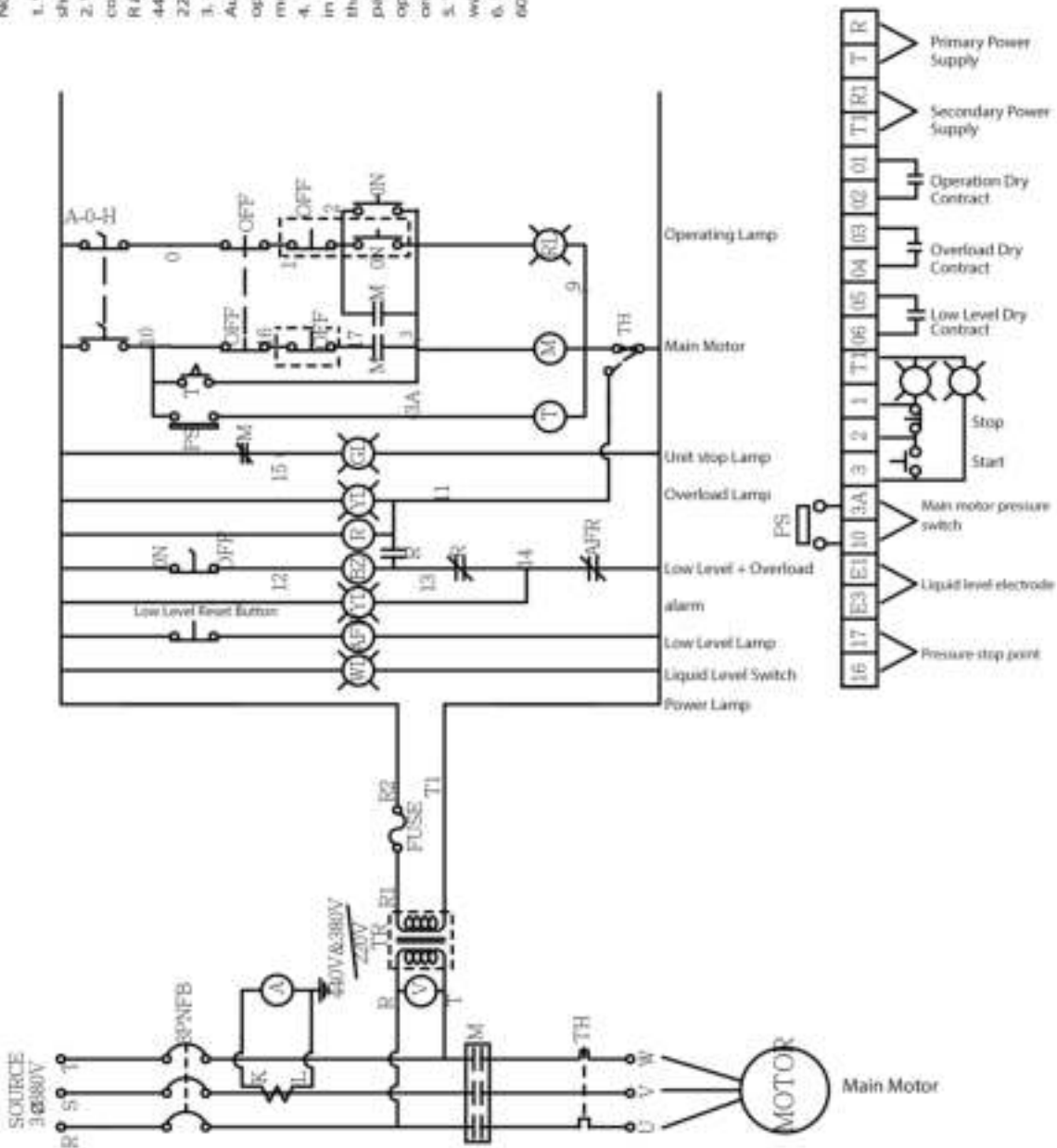

◆ Standard [Direct Start] Circuit Diagram. Any special change will be issued with separate diagram.

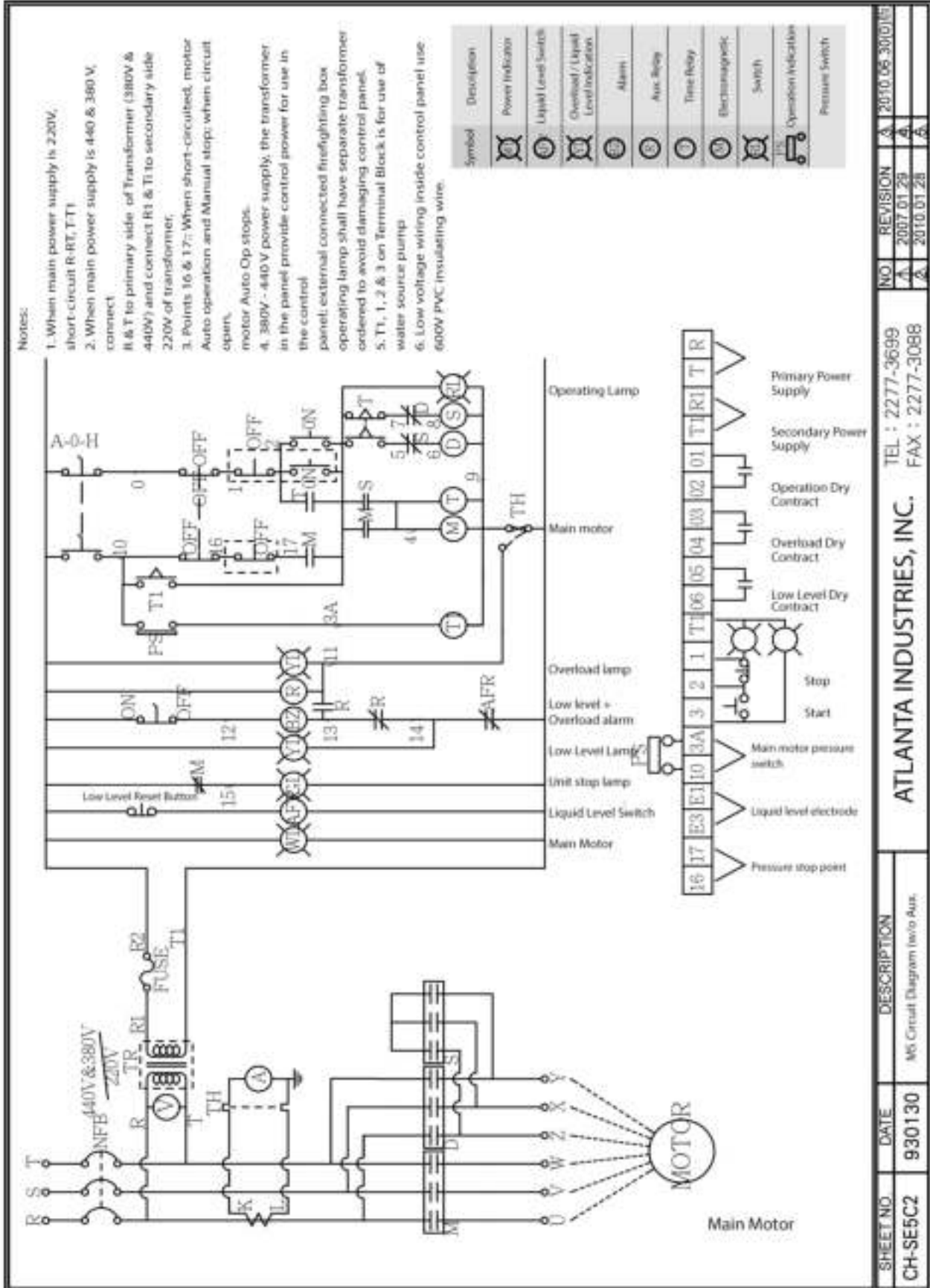

◆ Standard Y-Δ Circuit Diagram - without Auxiliary Pump.

SHEET NO.	DATE	DESCRIPTION
CH-SE5C2	930130	M5 Circuit Diagram (w/o Aux.

NO.	REVISION	DATE
1	2007.01.29	2010.06.30(01)
2	2010.01.28	

ATLANTA INDUSTRIES, INC.
 TEL : 2277-3699 FAX : 2277-3088



Republic of the Philippines
Department of the Interior and Local Government
Bureau of Fire Protection
NATIONAL HEADQUARTERS
Agham Road, Brgy. Bagong Pag-asa, Quezon City



CERTIFICATE

No. 201705072020R-01

This is to acknowledge the technological capability and application for fire protection system of:

Brand Name : Atlanta 25 in 1 Fire Pump
Model : Fire Protector
Type : Stationary Centrifugal Fire Pump
Manufacturer : TZU SHEN Fire Pump Systems
Taiwan
Application : Fire Sprinkler System
Applicable Standards : CNS 5679, ISO 9002:2000
And Certifications : BSMI Registered, TAF QC 002,
IAF Recognition QMS 010

This Certificate is issued as proof of recognition given this 07 JUL 2017 and valid up to three (3) years from date of issuance, unless otherwise earlier suspended and/or revoked by the issuing authority.



BOBBY V. BARUELO
DIRECTOR (DSC) BFP
FIRE CHIEF

Performance Curve

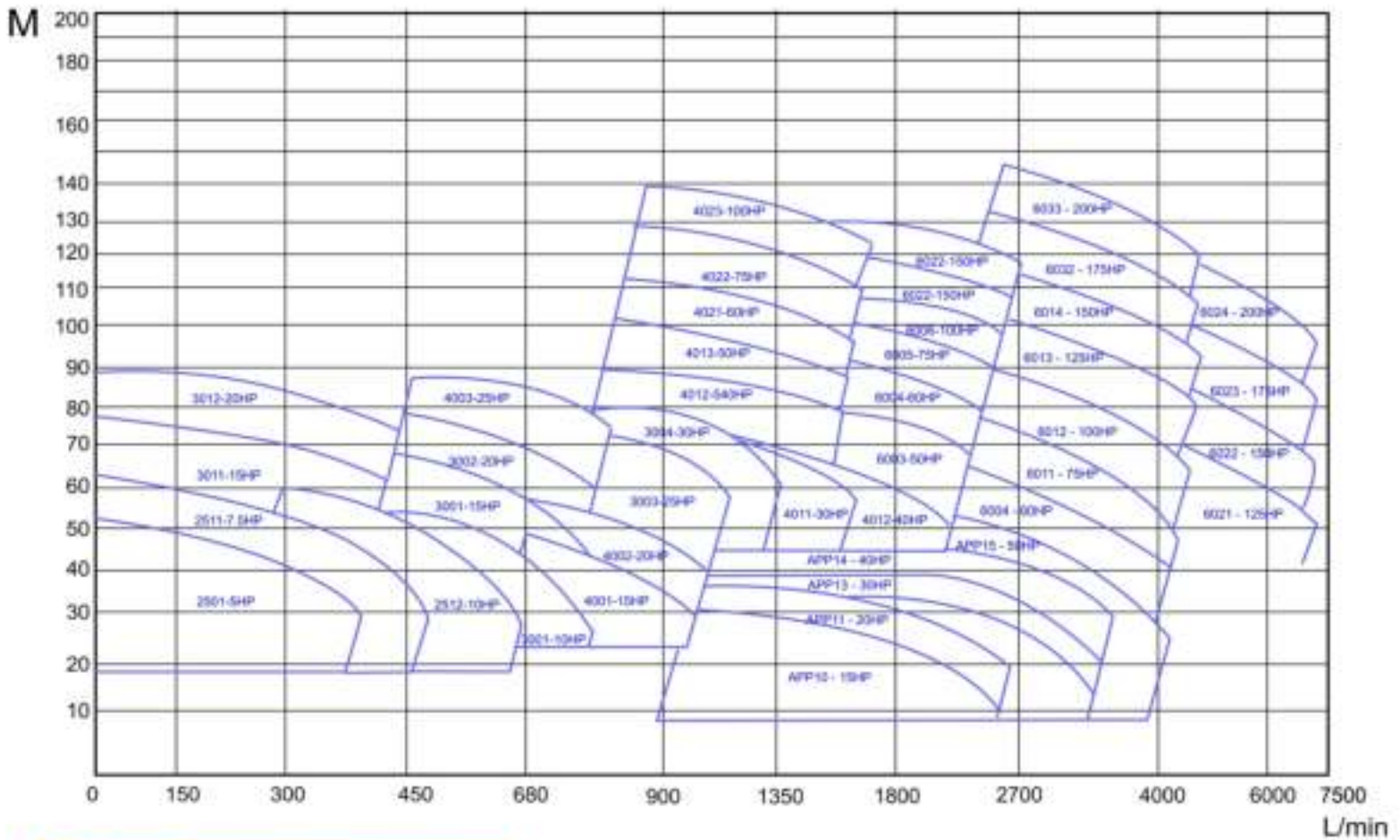

Ordering Form

- Power: Supply Specification: 3Ø X _____ VX 60Hz
Horsepower: _____ HP
- Starting Method: Y-Δ Direct Starting
- Purpose of Use: Indoor Fire Hydrant Outdoor Fire Hydrant Transfer
 Fire Sprinkler Foam Sprinkler
- Pump Model: _____
- Head: _____ m
- Capacity: _____ Liter/min
- Pipe Diameter: _____ mm
- Distance from pump inlet to the highest point of use: _____ M
- Jockey Pump Needed: No Yes _____ HP
- Other Requirements _____



35th Flr. Atlanta Center Bldg., No. 31 Annapolis St. Greenhills, San Juan City
 Tel. No.: 8723-0781 to 88 | Fax No.: 7744-4703 / 8584-2997
 Website: www.atlanta.ph Email Sales: marketing@atlanta.ph
 Like Us on Facebook: atlantaindustriesincorporated
 Subscribe to Our Youtube Channel: Atlanta Industries Inc.